

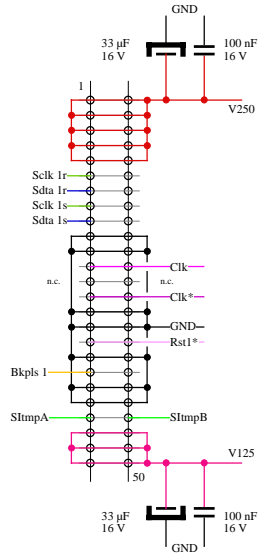

Mod 1

socket  
271.5

TOP  
Layer



Mod 2

socket  
453.5

BOTTOM  
Layer

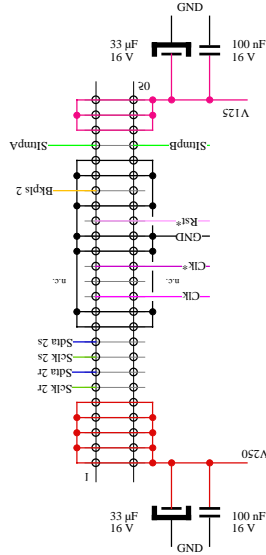

Mod 3/5

ICB  
LOW  
627.5

socket  
627.5 and 641.0

ICB  
HIGH  
641.0

TOP  
Layer

TOP  
Layer

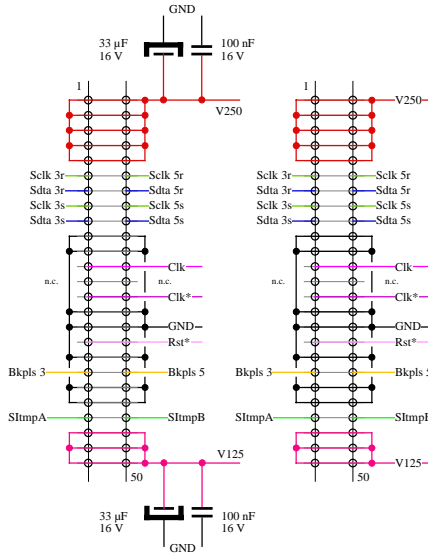

Mod 4/6

socket  
812.0

BOTTOM  
Layer

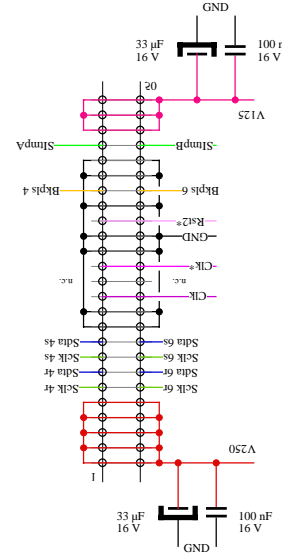

CCUM  
socket  
941.0

TOP  
Layer

BOTTOM  
Layer

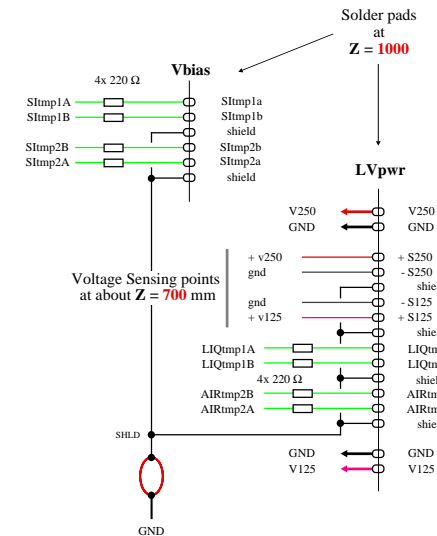
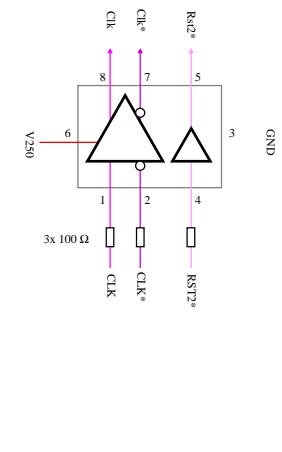
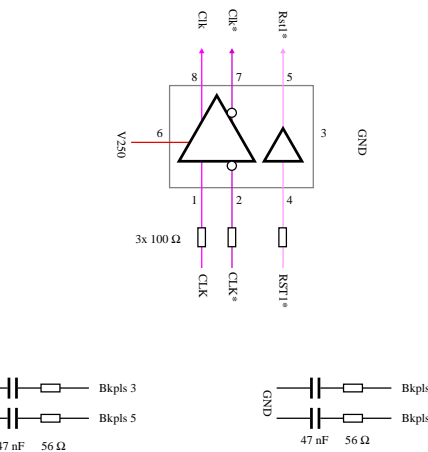
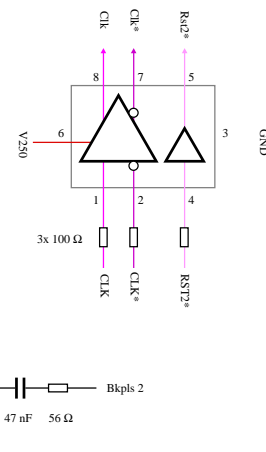
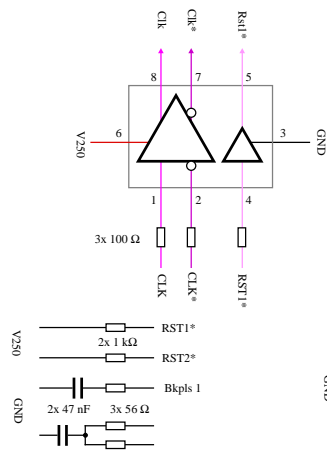
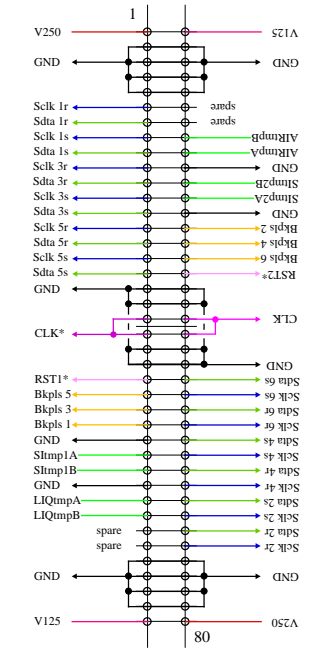

### TOB ICBus PCB partial electrical diagram

(TOB, Layer 1-6, High & Low)

R.Hammarström/cern/ep/cmt

File: Robert\_ppc/Si-TOB/Ladder/ICBus/ICBus-elec-diag Date: 12-12-2000 Mod: 30-5-2001