



9th April 2014

ODMB user's manual

Optical DAQ MotherBoard for the ME1/1 stations of the CMS muon endcap detector

Firmware tag: V03-03

ODMB.V2, ODMB.V3, and ODMB.V4 compatible

Manuel Franco Sevilla, Frank Golf, Guido Magazzù, Tom Danielson, Adam Dishaw, Jack Bradmiller-Feld
UC Santa Barbara

Table of Contents

Front panel	2
General	3
Firmware version	3
VME access through the board discrete “emergency” logic	3
Jumpers and test points	4
Device 1: DCFEB JTAG	5
Example: Read DCFEB UserCode	5
Device 2: ODMB JTAG	6
Example: Read ODMB UserCode	6
Device 3: ODMB/DCFEB control	7
Bit specification DCFEB pulses command “W 3200”	8
Information accessible via command “R 3YZC”	8
Device 4: Configuration registers	9
Note	9
Device 5: Test FIFOs	10
Notes	10
Device 6: BPI Interface (PROM)	11
Device 7: ODMB monitoring	12
Translation into temperatures, current, and voltages	12
Device 8: Low voltage monitoring	13
Device 9: System tests	14
Firmware block diagram	15

Front panel

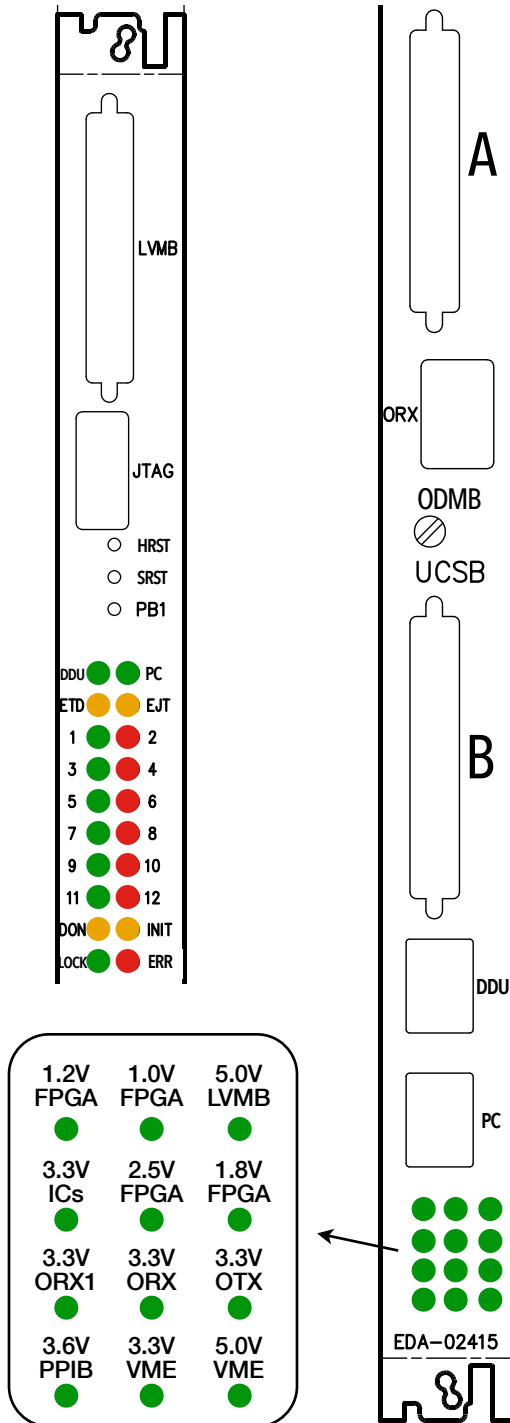

Push buttons

- **HRST**: Reloads firmware in PROM onto FPGA
- **SRST**: Resets registers/FIFOs in FW. **LEDs 1-12** blink at different speeds for ~3s
- **PB1**: Sends L1A and L1A_MATCH to all DCFEBs. Turns on **LED 12**

LEDs set in firmware

- **1**: 4 Hz signal from clock for data → DDU
- **3**: 2 Hz signal from clock for data → PC
- **5**: 1 Hz signal from internal ODMB clock
- **7**: Data taking: ON normal, OFF pedestal
- **9**: Triggers: ON external, OFF internal
- **11**: Data: ON real, OFF simulated
- **2**: Bit 0 of L1A_COUNTER
- **4**: Bit 1 of L1A_COUNTER
- **6**: Bit 2 of L1A_COUNTER
- **8**: Bit 3 of L1A_COUNTER
- **10**: Bit 4 of L1A_COUNTER
- **12**: Briefly ON when a VME command is received. Also ON when **PB1** is pressed

LEDs set in hardware

- **DDU**: Signal Detected on DDU RX
- **PC**: Signal Detected on PC RX
- **ETD**: DTACK enable for discrete logic (active low)
- **EJD**: JTAG enable for discrete logic (active low)
- **DON**: DONE signal from FPGA. ON when programmed
- **INIT**: INIT_B signal from FPGA (active low)
- **LOCK**: QPLL is locked
- **ERR**: Error with QPLL
- **Bottom 12**: Voltage monitoring

General

Firmware version

For a given firmware tag **VXY-ZK**:

- ❖ Usercode is **XYZKdbdb**
- ❖ Firmware version read via "R 4200" is **XYZK**

VME access through the board discrete "emergency" logic

The FPGA may be accessed via JTAG through the discrete logic as follows

- ❖ The VME address is 0xFFFC
- ❖ The bit 0 of the data sent is TMS
- ❖ The bit 1 of the data sent is TDI

For example, to read the Usercode, starting from JTAG idle (five TMS = 1 & one TMS = 0), the commands are:

```

W FFFC 1 To Select-DR-Scan
W FFFC 1 To Select-IR-Scan
W FFFC 0 To Capture-IR
W FFFC 0 To Shift-IR

W FFFC 0 Shifting IR (Read UserCode IR = 3C8)
W FFFC 0 Shifting IR
W FFFC 0 Shifting IR
W FFFC 2 Shifting IR
W FFFC 0 Shifting IR
W FFFC 0 Shifting IR
W FFFC 2 Shifting IR
W FFFC 2 Shifting IR
W FFFC 2 Shifting IR
W FFFC 3 Shifting IR and to Exit1-IR

W FFFC 1 To Update-IR
W FFFC 0 To Run_Test/Idle
W FFFC 1 To Select-DR-Scan
W FFFC 0 To Capture-DR

W FFFC 0 Shifting DR
R FFFC 0 Shifting DR (Read bit 0 of UserCode)

```

Since the Usercode register is 32 bits, the last two commands should be repeated 31 more times.

Jumpers and test points

Place the **jumper**s marked in **red** in the diagram (slave mode). The signals sent to the **test points** marked are:

TP13	RAW_LCT(1)	TP14	L1A_MATCH(1)	TP31	Defined by TP_SEL	TP32	
TP15	RAW_LCT(2)	TP16	L1A_MATCH(2)	TP33		TP34	
TP17	RAW_LCT(3)	TP18	L1A_MATCH(3)	TP35	Defined by TP_SEL	TP36	
TP19	RAW_LCT(4)	TP20	L1A_MATCH(4)	TP37		TP38	
TP21	RAW_LCT(5)	TP22	L1A_MATCH(5)	TP39		TP40	
TP23	RAW_LCT(6)	TP24	L1A_MATCH(6)	TP41	Defined by TP_SEL	TP42	
TP25	RAW_LCT(7)	TP26	L1A_MATCH(7)	TP43		TP44	
TP27	L1A	TP28	DDU_DATA_VALID	TP45	Defined by TP_SEL	TP46	
TP29	OTMBCDAV	TP30	ALCTDAV	TP47	DCFEB_TDI	TP48	
				TP49	DCFEB_TMS	TP50	2.5V

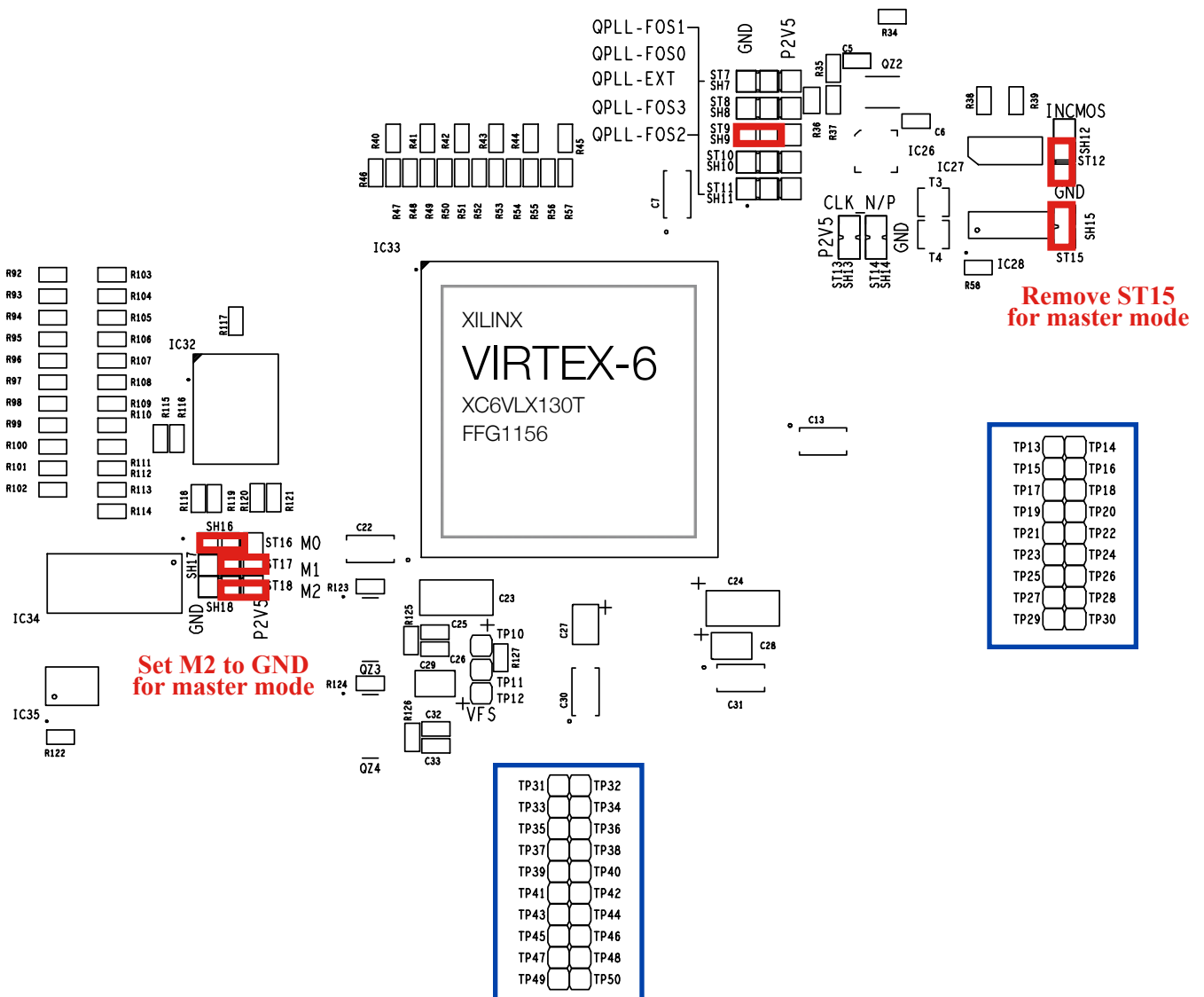

Device 1: DCFEB JTAG

“Y” refers to the number of bits to be shifted

Instruction	Description
W 1Y00	Shift Data; no TMS header; no TMS tailer
W 1Y04	Shift Data with TMS header only
W 1Y08	Shift Data with TMS tailer only
W 1Y0C	Shift Data with TMS header & TMS tailer
R 1014	Read TDO register
W 1018	Resets JTAG protocol to IDLE state (data sent with this command is disregarded)
W 1Y1C	Shift Instruction register
W 1020	Select DCFEB, one bit per DCFEB
R 1024	Read which DCFEB is selected

Example: Read DCFEB UserCode

DCFEB registers are set and read via JTAG. The following procedure reads the 32-bit USERID of DCFEB 3:

```

W 1020 4 Select DCFEB 3 (one bit per DCFEB)

W 191c 3C8 Set instruction register to 3C8 (read UserCode)
W 1F04 0 Shift 16 lower bits
R 1014 0 Read last 16 shifted bits (DBDB)
W 1F08 0 Shift 16 upper bits
R 1014 0 Read last 16 shifted bits (XYZK)

```

Device 2: ODMB JTAG

“Y” refers to the number of bits to be shifted

Instruction	Description
W 2Y00	Shift Data; no TMS header; no TMS tailer
W 2Y04	Shift Data with TMS header only
W 2Y08	Shift Data with TMS tailer only
W 2Y0C	Shift Data with TMS header & TMS tailer
R 2014	Read TDO register
W 2018	Resets JTAG protocol to IDLE state (data sent with this command is disregarded)
W 2Y1C	Shift Instruction register
W 2020	Change polarity of V6_JTAG_SEL

Example: Read ODMB UserCode

Read FPGA UserCode:

```

W 291C 3C8 Set instruction register to 3C8 (read UserCode)
W 2F04 0 Shift 16 lower bits
R 2014 0 Read last 16 shifted bits (DBDB)
W 2F08 0 Shift 16 upper bits
R 2014 0 Read last 16 shifted bits (XYZK)

```

Device 3: ODMB/DCFEB control

Instruction	Description
W/R 3000	0 → nominal mode, 1 → calibration mode
W 3004	ODMB soft reset
W 3008	ODMB optical reset
W 3010	Reprograms all DCFEBs
W 3014	L1A reset and DCFEB RESYNC
W/R 3020	TP_SEL register (selects which signals are sent to TP31, TP35, TP41, TP45)
W/R 3100	LOOPBACK: 0 → no loopback, 1 or 2 → internal loopback
W/R 3110	DIFFCTRL (TX voltage swing): 0 → minimum ~100 mV, F → maximum ~1100mV
R 3120	Read DONE bits from DCFEBs (7 bits)
R 3124	Read if QPLL is locked
W 3200	Sends pulses to DCFEBs (see below)
W/R 3300	Data multiplexer: 0 → real data, 1 → dummy data
W/R 3304	Trigger multiplexer: 0 → external triggers, 1 → internal triggers
W/R 3308	LVMB multiplexer: 0 → real LVMB, 1 → dummy LVMB
W/R 3400	0 → normal, 1 → pedestal (L1A_MATCHes sent to DCFEBs for each L1A).
W/R 3404	0 → normal, 1 → OTMB data requested for each L1A (requires special OTMB FW)
W/R 3408	Bit 0 → kills L1A. Bit 1 → kills L1A_MATCH
R 3YZC	Read ODMB_DATA corresponding to selection YZ (see below)

Bit specification DCFEB pulses command "w 3200"

- ▶ DCFEB_PULSE[0] - Sends INJPLS signal to all DCFEBs.
- ▶ DCFEB_PULSE[1] - Sends EXTPLS signal to all DCFEBs.
- ▶ DCFEB_PULSE[2] - Sends test L1A and L1A_MATCH to non-killed DCFEBs.
- ▶ DCFEB_PULSE[3] - Sends LCT request to OTMB.
- ▶ DCFEB_PULSE[4] - Sends external trigger request to OTMB.
- ▶ DCFEB_PULSE[5] - Sends BC0 to all DCFEBs.

Information accessible via command "R 3YZC"

- ▶ YZ = 3F: Least significant 16 bits of L1A_COUNTER
- ▶ YZ = 21-29: Number of L1A_MATCHes for given DCFEB, OTMB, ALCT
- ▶ YZ = 31-37: Gap (in number of bunch crossings) between the last LCT and L1A for given DCFEB
- ▶ YZ = 38: Gap (in number of bunch crossings) between the last L1A and OTMBDAV
- ▶ YZ = 39: Gap (in number of bunch crossings) between the last L1A and ALCTDAV
- ▶ YZ = 41-49: Number of packets stored for given DCFEB, TMB, or ALCT
- ▶ YZ = 4A: Number of packets sent to the DDU
- ▶ YZ = 4B: Number of packets sent to the PC
- ▶ YZ = 51-59: Number of packets shipped to DDU and PC for given DCFEB, TMB, or ALCT
- ▶ YZ = 61-67: Number of data packets received with good CRC for given DCFEB
- ▶ YZ = 71-77: Number of LCTs for given DCFEB
- ▶ YZ = 78: Number of available OTMB packets
- ▶ YZ = 79: Number of available ALCT packets

- ▶ YZ = 4F: Read number of times the QPLL lock has been lost

- ▶ YZ = 5A: Read last CCB_CMD[5:0] + EVTRST + BXRST strobed
- ▶ YZ = 5B: Read last CCB_DATA[7:0] strobed
- ▶ YZ = 5C: Read toggled CCB_CAL[2:0] + CCB_BX0 + CCB_BXRST + CCB_L1ARST + CCB_L1A + CCB_CLKEN + CCB_EVTRST + CCB_CMD_STROBE + CCB_DATA_STROBE
- ▶ YZ = 5D: Read toggled CCB_RSV signals

Device 4: Configuration registers

Instruction	Description
W/R 4000	LCT_L1A_DLY[5:0] → Set to LCT/L1A gap - 100
W/R 4004	OTMB_DLY[5:0] → Set to L1A/OTMBDAV gap read with "R 338C"
W/R 400C	ALCT_DLY[5:0] → Set to L1A/ALCTDAV gap read with "R 339C"
W/R 4010	INJ_DLY[4:0] - Delay: 12.5*INJ_DLY [ns]
W/R 4014	EXT_DLY[4:0] - Delay: 12.5*EXT_DLY [ns]
W/R 4018	CALLCT_DLY[3:0] - Delay: 25*CALLCT_DLY [ns]
W/R 401C	KILL[9:1] (ALCT + TMB + 7 DCFEBs)
W/R 4020	CRATEID[6:0]
W/R 4028	Number of words generated by dummy DCFEBs, OTMB, and ALCT
R 4100	Read ODMB unique ID ¹
R 4200	Read firmware version
R 4300	Read firmware build
R 4400	Read month/day firmware was synthesized
R 4500	Read year firmware was synthesized

Note

1. If unique ID not set, request UCSB to write it.

Device 5: Test FIFOs

Z refers to FIFO: 1 → PC TX, 2 → PC RX, 3 → DDU TX, 4 → DDU RX, 5 → OTMB, 6 → ALCT

Instruction	Description
R 5000	Read one word of selected DCFEB FIFO
R 500C	Read numbers of words stored in selected DCFEB FIFO
W/R 5010	Select DCFEB FIFO
W 5020	Reset DCFEB FIFOs (7 bits, one per FIFO, which are auto-reset)
R 5Z00	Read one word of FIFO
R 5Z0C	Read numbers of words stored in FIFO
W 5Z20	Reset FIFO

Notes

- All these FIFOs but PC TX can hold a maximum of 2,000 18-bit words (36 kb). PC TX is 4 times larger.
- The **OTMB**, **ALCT**, and **7 DCFEB FIFOs** store the data as it arrives in parallel to the standard data path
 - They can hold a maximum of 3 OTMB, 4 ALCT, and 2 DCFEB data packets
- The **DDU TX FIFO** stores DDU packets just before being transmitted
 - They include the DDU header (4 words starting with 9, 4 starting with A), ALCT data, TMB data, DCFEB data, and trailer (4 words starting with F, 4 starting with E)
- The **PC TX FIFO** stores DDU packets wrapped in ethernet frames just before being transmitted
 - They include the ethernet header (4 words) and trailer (4 words)
 - They need to be at least 32 words long
- The **DDU** and **PC RX FIFOs** can be used for loopback tests

Device 6: BPI Interface (PROM)

Important: Instruction 6000 takes ~1 second, during which Device 4 and 6 write commands are ignored

Instruction	Description
W 6000	Write configuration registers to PROM
W 6004	Set configuration registers to retrieved values from PROM
W 6020	Reset BPI interface state machines
W 6024	Disable parsing commands in command FIFO while filling FIFO with commands (no data)
W 6028	Enable parsing commands in the command FIFO (no data)
W 602C	Write one word to command FIFO
R 6030	Read one word from read-back FIFO
R 6034	Read number of words in read-back FIFO
R 6038	Read BPI Interface Status Register
R 603C	Read Timer (16 LSBs)
R 6040	Read Timer (16 MSBs)

Device 7: ODMB monitoring

Reads output of the ADC inside the FPGA

Instruction	Description
R 7000	FPGA temperature
R 7100	LV_P3V3: input to FPGA regulators
R 7110	P5V: input to PPIB regulator and level for 5V chips
R 7120	IPPIB: current going to PPIB (on V2s and V3s, board temperature THERM2)
R 7130	P3V6_PP: voltage level for PPIB
R 7140	P2V5: voltage level for FPGA and 2.5V chips
R 7150	THERM1: board temperature close to the regulators
R 7160	P1V0: voltage level for FPGA
R 7170	P5V_LVMB: voltage level for LVMB

Translation into temperatures, current, and voltages

The output of the 7YZ0 commands is a 12-bit number that we call R_{YZ} . The measurement is:

- The FPGA temperature is $T_{\text{FPGA}} = \frac{R_{00} \times 503.975}{4096} - 273.15$ [° C]
- The PPIB current is $I_{\text{PPIB}} = \frac{R_{12} \times 5000}{4096} - 10$ [mA]
- The temperature of the thermistors THERM1, THERM2 is given by

R_{XY}	377	455	55A	687	7DD	959	AF8	CB5	E87	FFF
T [° C]	15	20	25	30	35	40	45	50	55	60

- The voltage levels are $V_{YZ} = \frac{R_{YZ}}{2048} \times V_{YZ, \text{Nom}}$ [V], where $V_{YZ, \text{Nom}}$ is the nominal voltage level for that register. That is, $V_{10, \text{Nom}} = 3.3\text{V}$, $V_{13, \text{Nom}} = 3.6\text{V}$, $V_{11, \text{Nom}} = V_{17, \text{Nom}} = 5\text{V}$, $V_{14, \text{Nom}} = 2.5\text{V}$, and $V_{16, \text{Nom}} = 1\text{V}$.

Device 8: Low voltage monitoring

Instruction	Description
W 8000	Send control byte to ADC
R 8004	Read ADC
W 8010	Select DCFEBs/ALCT to be powered on (8 bits, ALCT + 7 DCFEBs)
R 8018	Read which DCFEBs/ALCT are powered on
W 8020	Select ADC to be read, 0 to 6
R 8024	Read which ADC is to be read

Table 1. Control-Byte Format

BIT 7 (MSB)	BIT 6	BIT 5	BIT 4	BIT 3	BIT 2	BIT 1	BIT 0 (LSB)
START	SEL2	SEL1	SEL0	RNG	BIP	PD1	PD0

PD1	PD0	MODE
0	0	Normal operation (always on), internal clock mode.
0	1	Normal operation (always on), external clock mode.
1	0	Standby power-down mode (STBYPD), clock mode unaffected.
1	1	Full power-down mode (FULLPD), clock mode unaffected.

INPUT RANGE	RNG	BIP
0 to +5V	0	0
0 to +10V	1	0
±5V	0	1
±10V	1	1

Device 9: System tests

Instruction	Description
W 9000	Test the DDU TX/RX with a given number of PRBS 2^7-1 sequences
R 900C	Read number of errors during last DDU PRBS test
W 9100	Test the PC TX/RX with a given number of PRBS 2^7-1 sequences
R 910C	Read number of errors during last PC PRBS test
W 9200	Check N*10000 bits from the PRBS pattern sent by the DCFEB
W/R 9204	Select DCFEB fiber to perform PRBS test
R 9208	Read number of error edges during last DCFEB PRBS test
R 920C	Read number of bit errors during last DCFEB PRBS test
W/R 9300	Set PRBS type for DCFEB: 1 → PRBS-7, 2 → PRBS-15, 3 → PRBS-23, 4 → PRBS-31
W 9400	Check N*10000 bits from the PRBS pattern sent by the OTMB
R 9404	Read number of enables sent by the OTMB
R 9408	Read number of good 10000 bits sent by the OTMB
R 940C	Read number of bit errors during last OTMB PRBS test
W 9410	Reset number of errors in OTMB counter

Firmware block diagram

The firmware can be downloaded from http://github.com/odmb/odmb_ucsb_v2

