

## 14 Integration and Assembly

This section describes the effort to integrate work at the subsystem level into a coherent design that meets the science requirements and that will result in an operational detector at SURF. A detailed assembly sequence is presented. While the overall scope of integration and assembly is contained in WBS 1.9, significant resources from every subsystem are required. Much of this effort comes from the distributed pool of engineers working for subsystems at many institutions. Coordination of this engineering effort is part of the integration task.

### 14.1 Integration

For LZ to achieve its science goals, it uses primary requirements that define what the subsystems must do; subsystem requirements drive more specific design specifications (see Chapters 3 and 4). A requirements registry has been created to help clearly understand and capture the design drivers. The subsystems must be safe, affordable, timely, compatible with the other subsystems, and possible to assemble and operate with the available infrastructure. The Integration Group provides the necessary management, engineering, design, organizational tools, and administrative effort to assist all subsystems in completing the LZ design. Phone meetings and technical workshops help identify interface issues and hidden constraints created by design choices in other subsystems. The Integration Group maintains a CAD model of the overall LZ detector and a CAD model of the Davis Campus. This helps define physical interferences and design gaps that are not adequately covered. At integration meetings, engineers from each subsystem, and many scientists, share ideas to help with some of the more difficult design challenges.

The Integration Group develops general standards and controls, such as engineering document standards to be used project-wide for CAD file exchange, engineering drawings and design notes, specifications and procedures, engineering change requests and engineering change notices (ECRs/ECNs), and a document-numbering and -organization system. The Integration Group defines component reference names and an overall coordinate system for the experiment. The group maintains a cable and feed-through list with the help of the subsystem management. A key parameters list is maintained as a reference for design, modeling, and science.

As designs mature, they must be documented and reviewed. The Integration Group works with project and subsystem management to arrange and execute design reviews at appropriate times. Conceptual Design Reviews evaluate whether the design meets the requirements, interfaces have been identified and successfully coordinated, and engineering details are sufficiently developed to proceed. Preliminary Design Reviews focus on manufacturability, cost, schedule, risk, and safety. Final Design Reviews ensure that documentation and drawings are complete and the fabrication plan fits within project budget and timeline.

LZ is being assembled and installed in an underground area administered by SURF. Integration includes working with SURF to be sure the infrastructure is adequate to support assembly, installation, and operation of the LZ experiment. SURF engineers are tasked with design and execution of infrastructure projects to support the LZ project. The Integration Group coordinates communication of requirements with SURF and the detector subsystems.

The overall planning of the on-site assembly and installation of the detector at the Davis Campus is part of the integration effort. This work includes defining the sequence of steps to put the detector together, creating a schedule for this work, and developing an understanding of the resources needed to accomplish it. Subsystems support this effort by providing details for handling components and aiding in resource and schedule development.

## 14.2 Assembly

The LZ assembly will happen in three stages — off-site subassembly, surface assembly in the Surface Assembly Lab (SAL), and underground assembly in the Davis Campus — with transportation between stages. The general strategy is to do as much work as practical off site at universities and national laboratories, where highly skilled, specialized labor can easily work with students and scientists. This also reduces travel costs. Parts delivered to the site will be tested, clean, and ready to use, with a few exceptions.

Xe PMTs will be assembled, tested, and characterized prior to delivery to SURF. The PMT vendor(s) will do some QA testing, but burn-in, final electrical characterization, and cold testing of each PMT will be done by LZ. Assembly includes connecting a PMT base to the PMT, attaching fluorocarbon polymer (FCP) reflectors, and final cleaning. Because they have FCP as a reflector, the assemblies must be kept under a nitrogen purge during storage and shipping to prevent radon contamination. Metalized plastic bags can be filled with nitrogen and heat sealed to protect parts during shipment. Internal PMT cables will have a pin-and-socket connection at both ends. They will ship separately and be routed to the PMTs after the PMTs are installed on the support arrays. The cables will be connected to the feed-throughs mounted in flanges after the cables are routed. The cables must be kept clean and under nitrogen purge during storage and shipping because they contain FCP as the primary insulator. Because of concerns about radon contamination, we are still considering an option to do the assembly of all FCP parts to the PMTs at SURF in the reduced-radon clean room of the SAL.

The tested PMTs will be placed into the titanium PMT support structure, including preliminary placement and routing of the cables. The baseline plan is to also do this work at the SAL reduced-radon clean room, but off-site assembly is still under consideration. This work will create an upper and lower populated PMT array. The upper skin PMTs will be attached to the three weir segments. The lower skin PMTs will be directly attached to the lower PMT array.

The wire grids for cathode, gate, anode, and PMT shields will also be manufactured off site. The grids will be cleaned, inspected, packaged, and shipped to SURF. The packaging must keep the wires clean from any debris and protect the fragile wires from shock during shipping.

The field-grading region of the TPC is made from conductive metal rings, insulating FCP spacers, and resistors. These parts will be fabricated by vendors and then inspected and cleaned off site before shipping to SURF. Radon exposure of completed FCP parts will be minimized after final machining. They can be stored and shipped with nitrogen purge or in sealed metal packaging.

The cryostat will be delivered as fully tested and cleaned code-stamped vessels. They will be manufactured in the UK and shipped. A vendor in the United States will perform final cleaning of the vessels just prior to shipment to SURF. The inner and outer vessel will be shipped separately (not nested) in nitrogen-filled sealed bags from the cleaning facility. The reflective liner for the inner vessel will be attached to the wall in the SAL. The plan is to suspend the bottom of the inner cryostat upside down in the vessel-assembly area and to access the inside of the vessel from underneath with a manlift. This will allow a worker to tile the inside while standing on a stable surface.

The HV umbilical will be delivered as a clean, tested, and sealed assembly under vacuum. The heat-exchanger tower subassembly will be built, cleaned, and tested off site, and transported as a sealed assembly under vacuum. The Gd-LS tanks will be manufactured, cleaned internally, tested off site, and shipped in protective packaging. The outside of the Gd-LS tanks will be cleaned on site, underground. The ladders, PMTs, and Tyvek reflectors of the outer detector will be shipped separately.

It is unlikely that the timing of delivery can match the time each piece is needed. A storage location has been identified at SURF (see Chapter 13).

The subassembly work and transportation described above will primarily be the responsibility of the subsystems. Once things arrive at SURF, primary responsibility shifts to the Integration and Installation

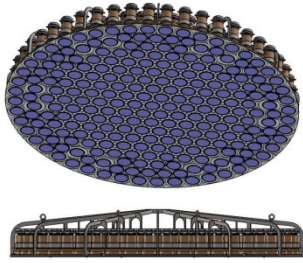

**S1 - PMT ARRAYS - UPPER & LOWER**

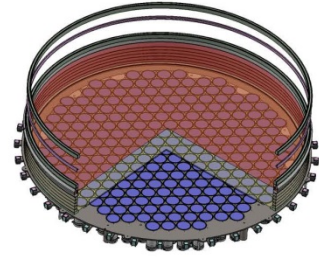
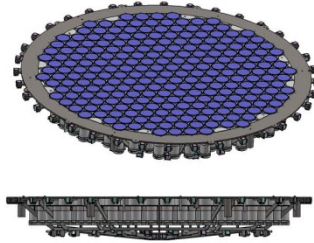

**S2 - TPC REVERSE FIELD CAGE ASSY**

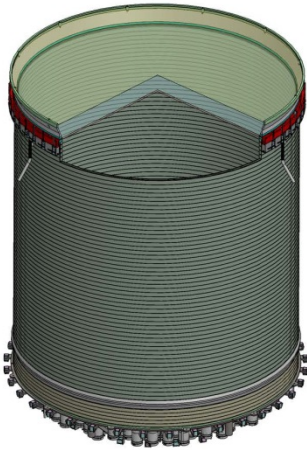

**S3 - TPC FULL FIELD CAGE ASSY  
with WEIR**

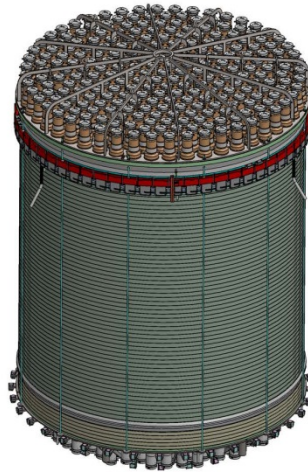

**S4 - FULL TPC with SUPPORT RODS**



**S5 - FULL TPC with TUBES  
CABLES NOT SHOWN**

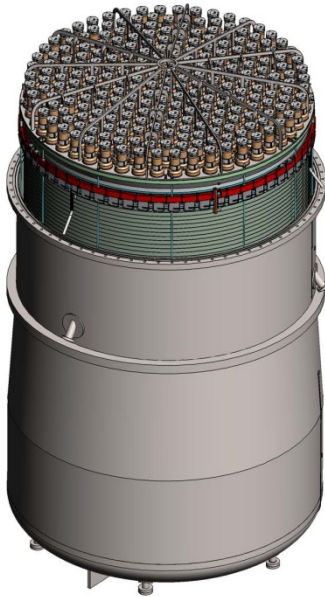

**S6 - TPC in INNER VESSEL BOTTOM**



**S7 - LID OVER INNER VESSEL**



**S8 - COMPLETE ASSY with CABLES  
IN TOP HATS**

Figure 14.2.1. LZ surface assembly sequence.

Team (WBS 1.9). The plan is to work with SURF to hire a pool of local technicians to perform much of the work. This pool will include experts in cleaning, electronics, vacuum, rigging, and mechanical assembly. A lead technician will handle managerial supervision and work direction, but technical supervision will be supplied by engineering and scientific staff. An LZ engineer will be on site to coordinate the work and provide technical oversight. Experts from subsystems will be on site during assembly work focused on those subsystems. Existing SURF engineering and technical personnel will also provide support.

On-site assembly starts aboveground with assembly of the TPC. Cleanliness is critical for this assembly work, both to reduce radioactivity backgrounds in the detector and to control particles that could cause field enhancements and reduce operating voltage. This work will be done in the SAL constructed at SURF with a large reduced-radon clean room (see Chapter 13). Figure 14.2.1 shows the major steps of assembly in the SAL. The first step is receiving and inspection of the parts and subassemblies. The goal of the inspection is to ensure that the parts have not been damaged in shipment and will meet functional requirements. This includes cleanliness.

The next several subsections describe the various stages of assembly. Each subsection concludes with a description of the suite of checkouts that will be performed prior to declaring the stage complete. Final definition of these checkouts is a crucial aspect of the assembly and will be made by WBS 1.9 in close consultation with the relevant subsystem owners.

#### **14.2.1 TPC Assembly (Steps S2 – S5)**

The assembly will start with the cathode grid supported upside down on a flat surface (see Chapter 6 for descriptions of the components referenced here). The field-grading assembly composed of FCP arcs and complete metal rings will be assembled onto the cathode grid. The arcs and the rings are held together with plastic pins and screws. Resistors that fit into sockets to electrically connect the metal rings will be installed as the rings are stacked. When the field cage has reached the correct height, the PMT shield grid will be installed onto the stack. The lower PMT array will be lifted onto the stack and connected to the PMT shield grid with PEEK screws. The cables for the lower TPC PMTs and the skin PMTs will now be facing up and will get dressed into final positions. Tubes and manifolds for distribution of LXe will be added to the lower PMT array. Temperature sensors and their cables will be installed. Loop antennas for detection of discharge and their cables will be installed. The voltage-control cable for the lower PMT shield grid will also be installed. The lower field grading subassembly (reverse-field region) will be picked up and rotated 180° so the cathode grid is up and lower PMT array is down. This will require a special rigging fixture. The field-grading assembly then proceeds from the cathode grid upward. When the total height is reached, a cylindrical ground plane will be attached to the outside of the field cage to control the field in the region of the skin PMTs. An upper grid subassembly is assembled from the gate grid, three weir sections, the anode grid, and a nonreflective structural spacer. Liquid level sensors and upper skin PMTs will be installed onto the weir segments. The complete upper grid subassembly is then installed onto the top of the field cage. The upper PMT array will then be lifted and set on top of the nonreflective spacer and secured with screws. The cables for the upper TPC PMTs, the upper skin PMTs, and the weir level sensors will get dressed into final position. Temperature sensors and their cables will be installed. The voltage-control cables for the gate, anode, and upper PMT shield grid will then be installed. Tubes and manifold distribution for Xe return gas will be installed on the upper PMT array. The TPC is now assembled and will be run through a series of tests to ensure light-tightness of the field-grading cylinder, function of all the PMTs, function of the HV grids and resistor network, and function of the sensors. Stainless steel threaded rod will be installed to tie the upper PMT array titanium structure to the lower PMT titanium structure temporarily for handling.

### **14.2.2 TPC Insertion into Cryostat with Fluid and Electrical Final Routing (Steps S6 – S8)**

The TPC will then be moved over the bottom of the inner cryostat and the bottom inner cryostat raised into position around it. During this process, the PMT and sensor cables coming from the lower PMT array will be routed through the central port in the bottom of the inner cryostat. Xe fluid circulation lines also routed through this port will have been placed into position earlier, but may need adjusting and securing as part of the cable routing. Access for this operation will be through the HV connection port and the bottom port of the vessel. The three Xe tubes from the weir trough must be routed to the ports in the inner cryostat wall. These tubes are FCP bellows that will initially be pointing straight down and then guided into the ports as the inner cryostat is raised. The TPC is supported on six posts projecting upward from the bottom head of the inner cryostat. Tapered guide pins will be installed in the bottom mounting holes of the TPC to engage the holes in the posts and guide the TPC into the correct position. Once the TPC is in the correct place, the guide pins will be removed and bolts will be installed to secure the TPC to the posts. The titanium plate for the upper PMT array will be guided from the inner cryostat near the main flange with tabs that allow vertical motion but constrain radial motion. Access for this work is from the top over the main flange. After these upper guides are secured, the TPC is fixed in the vessel and the temporary threaded rods between the upper and lower PMT arrays will be removed. The location of the weir surfaces that establish the LXe plane will be surveyed relative to known positions on the outside of the inner cryostat. This will allow rough leveling of the weir surface during future assembly steps. The next step is to stage the lid of the inner cryostat over the bottom and install a temporary safety support. The PMT cables, grid cables, sensor cables, and Xe gas lines coming from the upper PMT array need to be routed through a port in the inner cryostat lid. The sensors that monitor the position of the TPC relative to the inner cryostat wall will be installed and cables dressed. The lid can then be lowered onto the bottom of the inner cryostat and the large-diameter seal formed. This seal is designed as two seals (double O-ring) to facilitate a check for leaks by pumping between the seal and looking at the rate of pressure rise. All other ports on the inner cryostat must be sealed for transportation to keep the TPC clean. The ports with cables cannot be sealed with normal blank flanges. Special enclosures — top hats — will be built to house the cables and sealed to the inner cryostat during transport. The sealed inner cryostat will be pumped down to vacuum to ensure the seals are adequate. Other testing will be done at this point. This could include PMT functional tests, sensor tests, light-tightness tests between the skin and central TPC volume, and HV tests. Closed-cell foam insulation and superinsulation blankets will be fit-tested on the outside of the inner cryostat for later underground installation. After these tests, the inner cryostat with TPC assembly will be double-bagged so it is ready to be moved underground.

### **14.2.3 Underground Outer Detector Tank Preparation and Staging (Steps U1 – U2)**

The first step of underground assembly is to prepare the water tank (see Chapter 13). All LUX components will have been removed and some infrastructure work on the overhead cranes completed. Some welding is needed in the water tank for attachment points for the cryostat support, the Gd-LS tanks, and the outer detector PMT ladders. New penetrations are needed for the HV umbilical and the HX conduit through the wall of the tank. After these welding operations, the tank will be passivated again to improve corrosion resistance to the pure water. The water tank will then be cleaned and made into a clean room with reduced-radon air delivered from the surface as compressed air through a pipe from the SAL. The tank will be kept with slightly positive pressure to reduce air infiltration. The access door in the side of the tank will be outfitted with a changing room and air lock.

The central top port of the water tank is the only port big enough to allow installation of the Gd-LS tanks. Once the cryostat is installed, this path will be blocked. So the bottom and side Gd-LS tanks must be transported underground and staged in the water tank. Figure 14.2.3.1 shows the sequence of installation in the water tank. The Gd-LS tanks will arrive clean on the inside and covered with protective plastic and rigging frames. The acrylic tanks will be brought into the Yates headframe with a telehandler and set on a



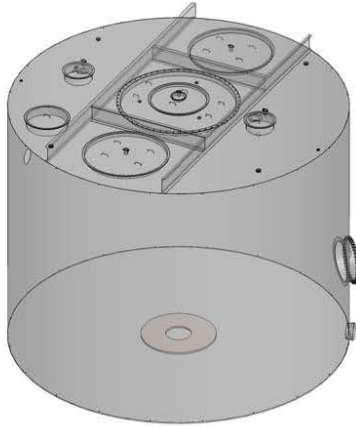

**U1 - EMPTY WATER TANK**

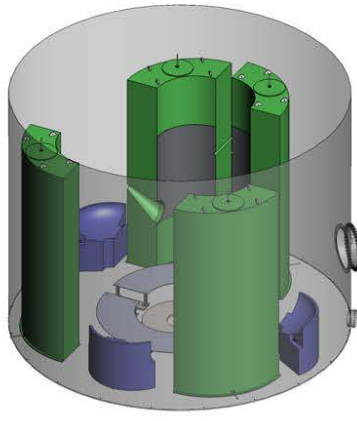

**U2 - LS TANKS**

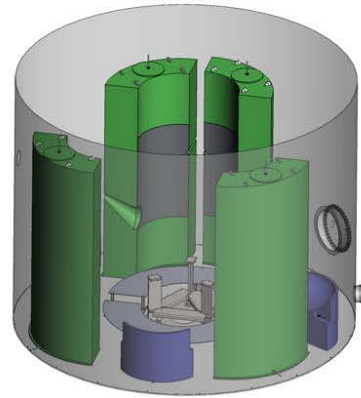

**U3 - VESSEL SUPPORT LEGS**



**U4 - OUTER VESSEL  
BOTTOM & MIDDLE**

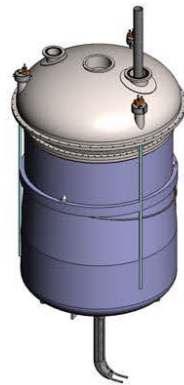

**U5 - INNER VESSEL  
OUTER LID, CABLES**

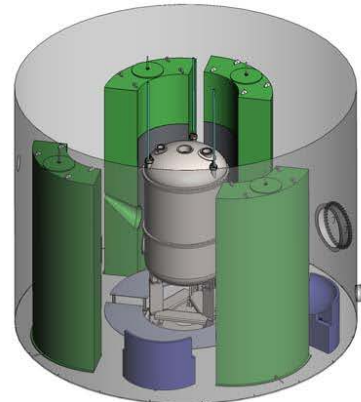

**U6 - INNER VESSEL**

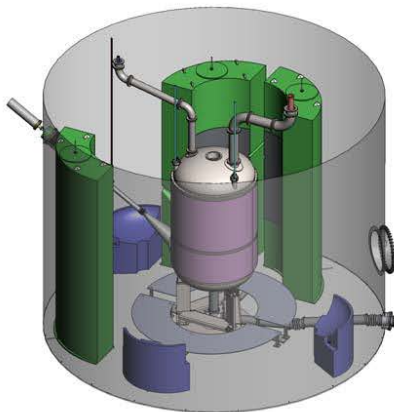

**U7 - HV UMBILICAL & HX CONDUIT  
(ONE LS TANK REMOVED)**

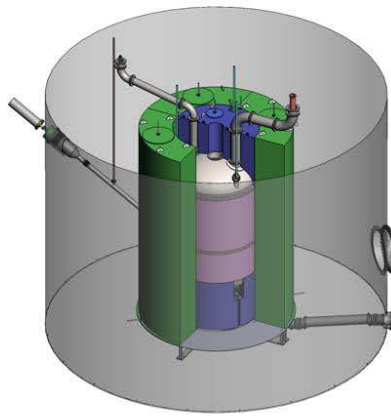

**U8 - LS TANKS IN PLACE  
(TWO LS TANK REMOVED)**

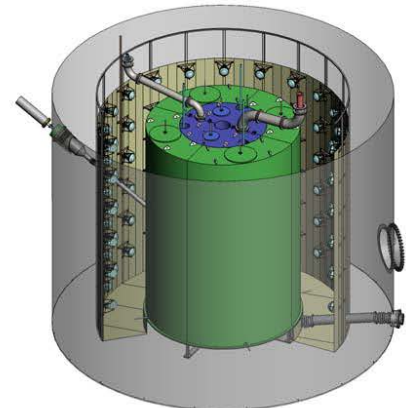

**U9 - WATER PMTs**

**Figure 14.2.3.1. Underground installation sequence in water tank.**

cart in front of the Yates cage. The four large side tanks will be moved first. Rigging will be used to attach the steel frame around the tank to the underside of the cage. The cage will be raised to lift the tank until it is vertically under the cage. A drag line will guide the lower end of the tank. The cage will be lowered slowly until the bottom of the tank is at the 4850L. A drag line will be reconnected to the bottom to pull the tank out as it is lowered further. The tank will be placed on a receiving cart. The cart will transport the tank to the entrance to the Davis Campus with a cleaning area (so-called cart wash). The external frame and external packaging around the tank will be cleaned to remove mine dust from transport. The bottom of the tank must enter the Davis area first. One hook from the monorail in the Davis Cavern will connect to two points near the bottom of one side of the rigging frame. A second hook from the same monorail will connect to the top of the tank's rigging frame. The motion of the hooks will be choreographed to lower the acrylic tank into the water tank, keeping the rigging vertical over the lifting points by moving the hooks along the monorail. Once the tank is vertical and set down on the floor of the water tank, it will receive a final inspection and leak test. The external packaging and protective plastic will be removed from the acrylic tank. The outside of the tank will be cleaned with Alconox and water and visually inspected for any cracks. The three bottom tanks and the two top tanks will be transported inside the cage and unpackaged and cleaned in the cart-wash area. The three bottom tanks will be staged inside the water tank. The two top tanks will not be staged, as they will be installed from the top after the cryostat and cable-conduit installation is completed. A custom hoist system will be constructed inside the water tank to move the Gd-LS tanks inside the water tank. Stainless steel support stands that hold the four tall outer Gd-LS tanks will also be staged into the water tank. The HV umbilical and parts for the HX conduit may also be staged in the water tank.

#### **14.2.4 Cryostat Transportation and Underground Assembly (Steps U3 – U6)**

The installation of the cryostat starts with the cryostat support. The survey reference system for the detector will be established and a baseplate located on the floor of the water tank. The legs will be brought down in the cage cleaned and double-bagged. The outside bag will be removed at the entrance to Davis. The inside bag will be removed on the top deck near the opening to the water tank. The legs will be lowered into the water tank through the central port with a single hoist. They are then bolted to the baseplate and the supports that contact the outer cryostat will be adjusted to surveyed positions. The outer cryostat has been designed as three pieces so each piece can fit in the Yates cage. Each piece will be brought down in the cage cleaned and double-bagged. The bottom head of the outer cryostat is lowered into the water tank with a single hoist and positioned over the three support legs. The gaps to the legs will be measured and adjusted until an adequate fit is achieved. Once the bottom head is lowered, it will be bolted to the legs. The middle section will be brought in next, rigged into position above the bottom, sealed to the bottom, and leak-tested. The support of the bottom cryostat will be adjusted so the top surface of the outer middle section is level. A displacer around the outer cryostat cylindrical section reduces the amount of water between the Gd-LS tanks and the cryostat. This may be installed around the outer cryostat at this point or after the HV connection is completed. The top lid will be brought into the Davis Campus and staged on the top deck with its inner bag still in place.

The inner cryostat will not fit in the cage, so it must be hung under the cage. It will be horizontal for some of its journey from the SAL to Davis, and vertical for other parts. The TPC support system will be designed to accommodate support in both conditions and the transition between them. An external rigging company will be contracted to rotate the inner cryostat from the vertical assembly position to the horizontal position for removal from the SAL and transport to the Yates headframe. It is anticipated that this move will also be done with a telehandler. There is a detailed plan for transport of the inner cryostat from the surface to the 4850L (see Chapter 13). On the 4850L, a special cart with air skates will be used to bring the inner cryostat from the Yates shaft to the Davis Cavern. The special cart must be cleaned. The outer bag around the cryostat will also be removed in the cleaning area. The cart will move the inner cryostat onto the deck near the entry hole to the water tank. The two hooks on the monorail will be used

to lift the inner cryostat off the cart, rotate it back to vertical, and rest it on a temporary support on the top of the deck. A temporary clean room will be built around the inner cryostat. Reduced-radon air from the surface will be used to provide a clean atmosphere and to purge the cryostat once the cable ports are opened. The inner bag around the inner cryostat will be removed. Closed-cell foam insulation will be installed onto the sides and bottom of the cryostat. Then prefabricated superinsulation blankets will be installed. Temporary supports for the outer cryostat lid will be installed onto the inner cryostat. Reduced-radon purge air will be connected to the inner cryostat and the top cable top hat will be opened and removed. The outer cryostat lid that was previously staged will be unbagged, rigged over the inner cryostat, and set on the temporary supports. The upper cables will be routed through the ports on the outer cryostat lid. The permanent support rods that hold the inner cryostat from the outer cryostat will be installed. The supports will be adjusted to position the weir surface of the inner cryostat parallel to the sealing surface of the outer cryostat lid. The lower section of the three calibration ports will also be installed. The lower cable top hat will be opened and removed. The lower cables and LXe lines will be dressed for final installation. The LXe lines from the weir will also be dressed. The outer cryostat lid will then be lifted and the load from the inner cryostat will transfer from the temporary supports on the deck to the permanent supports from the lid. The temporary outer lid supports will be removed and the assembly of the outer cryostat lid and inner cryostat will be lowered into the water tank and into the outer cryostat bottom. As the inner cryostat is lowered, the bottom PMT cables and signal cables will need to be threaded through the central port of the outer cryostat bottom head. The reduced-radon air will continue to purge the inner cryostat during this process. The crane will set the assembly down so the outer cryostat lid rests on the outer cryostat middle section top flange. The inner cryostat will still be hanging from the lid. This flange can then be assembled and leak-checked.

#### **14.2.5 Utility Connection (Step U7)**

The HX conduit is then installed to the bottom of the cryostat. PMT cables and Xe transport lines share this conduit and connections will be made with an orbital welder whenever possible. Some connections will be VCR fittings. The conduit continues through the outer wall of the water tank to the cryo tower. The PMT cables branch off at a tee to a vertical pipe with an array of flanges and hermetic feed-throughs. This area has many details that must be carefully planned. The upper PMT cables and sensor lines are also installed into a flexible conduit with a vertical pipe and an array of flanges with hermetic feed-throughs.

The HV umbilical attaches to the large side port. To reduce krypton and radon absorption by the internal plastic components, this assembly will also be purged with nitrogen or reduced-radon air whenever it is opened. The umbilical slides as an assembly through the outer port in the wall of the water tank. The mass is supported by cables from the lid of the water tank. The outer vacuum jacket and inner Xe tube are designed so they can slide away from the vessel leaving ~18 inches of space for assembly. The central cable of the umbilical needs to be electrically connected to the cathode. The inner tube of the umbilical then seals against the inner cryostat. This joint is angled, making it difficult to install the bolts at the top of the flange. Studs will be used so the assembly is possible. The flange will have a double O-ring so the seal can be leak-checked at this point. Then the outer vacuum jacket will slide down toward the detector and make a seal to the outer cryostat. This seal will also need a double O-ring so it can be leak-checked. Sealing rings at the water tank wall are installed to seal the inner tube to the outer tube and the outer tube to the vacuum tank. There are no direct water-to-Xe seals.

The final step of cryostat installation is positioning and leveling. The connections for the HX conduit and HV umbilical add load and positional constraints to the hanging inner cryostat. The support rods will be adjusted using feedback from built-in electronic level sensors. We have designed in enough compliance to these connections so the inner vessel can be moved. The cryostat should now be sealed and the reduced-radon air flow can be stopped. The inner cryostat will be pumped down to start long-term outgassing of the internal plastics.



### 14.2.6 Outer Detector Assembly (Steps U8 – U9)

The Gd-LS tanks can now be placed into final position. The three bottom tanks are set on platforms connected to the cryostat legs. The upper Gd-LS tanks are then installed through the top port of the water tank. They are lowered slightly radially outward from their final positions to clear the PMT cable conduit and thermosiphon conduits and, once they are low enough, translated under the conduits to the correct final position. The upper Gd-LS tanks are supported by the top flange of the outer cryostat. The four side tanks will be moved in adjacent to the displacer around the outer cryostat and rest on stainless steel supports. There are notches for the HV umbilical so the tanks have to come in from the proper direction. After positioning, the tops of the tanks are connected for stability. Each tank is secured so it will not float in the water or tip over in an earthquake. Each tank has a fill line and vent line that come to a common overflow reservoir on the top of the water-tank lid. The final system will be visually inspected and leak-checked with a low-pressure gas.

The outer detector PMTs will be installed onto half-ladders and lowered into the water tank through one of the larger off-axis ports in the lid. The half-ladders are assembled together and secured to the roof and floor of the water tank and cables are run up to one of the top water-tank ports. Cables are sealed at these ports. The Tyvek reflectors to direct light lie on the floor, are hung vertically from the top of the ladders, and are stretched across the top of the ladders.

The detector is now ready to be filled with Xe, Gd-LS, and water. Xe filling must wait until the inner cryostat has been at vacuum long enough to get the residual gas content of the plastics to an acceptable level. Warm, low-pressure Xe gas may be circulated to heat the plastic and enhance diffusion. This Xe would be pumped out and repurified or sold. Once plastic outgassing is at an acceptable level, the vessel will be filled with Xe gas and slowly cooled with LN<sub>2</sub> until the Xe starts to condense. Filling continues until the Xe liquid is at the desired level. Gd-LS is received on site ready to use in 55-gallon drums. The Gd-LS and water must be filled at the same time to minimize stress on the acrylic walls. The levels do not need to match exactly, so one drum of Gd-LS can be added to the tanks one at a time as the water level rises. It is added by pressurizing the drums with nitrogen gas to force Gd-LS through the filling tubes at the overflow reservoir. Water is purified before it is added and covered with a nitrogen head once the tank is filled. A flowing nitrogen head is maintained over the Gd-LS to protect it from both radon and oxygen.

While the main detector installation and assembly sequence described above are occurring, the support equipment and utilities for the experiment will be installed in Davis. This includes cryogenic cooling equipment, vacuum pumps, LN<sub>2</sub> thermosiphons, Xe purification and circulation equipment, TPC HV supplies, PMT readout electronics, PMT HV supplies, calibration source tubes, connections and hardware, the emergency Xe recovery system, DAQ, and control systems. Details of these items are covered in other chapters.

The duration of the work in the SAL from the start of the assembly of TPC to the inner cryostat being sealed and ready to move underground is expected to be seven months. Before underground installation work can begin, LUX will need to be decommissioned and removed and Davis infrastructure work described in Chapter 13 will need to be completed. LZ installation underground has an estimated duration of seven months from staging of the Gd-LS tanks to being ready to fill.